

# Revolving head | Quick-change toolholder

21870

4x turret head (RD)



**Type**

Precise production thanks to the high repeatability and turn down precision (0.005 mm).

**No cassette change:** Inner and outer fit in one clamping position. Quick-clamping mechanism - for type RD, graduation 9° with 40 positions.

Available in 4 sizes. Up to 4 tool holders can be clamped at any one time.

**Use**

For machining precise turning parts thanks to high-precision tool exchange system with perfect user friendliness.

**Note:**

Quick-change toolholder see cat.-no. 21871 - 21876.

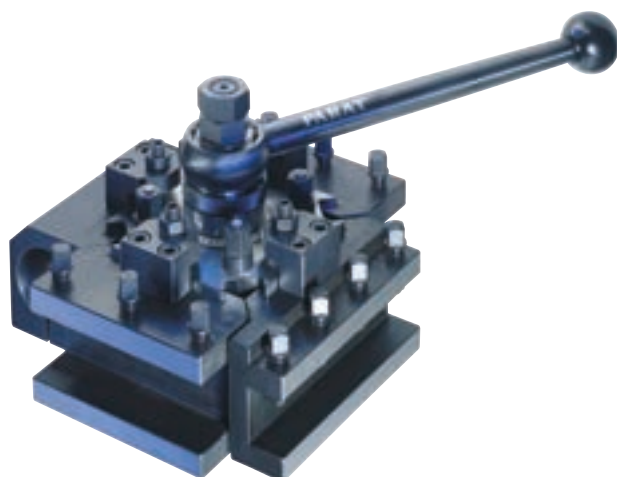

21870 101-104

Parat 4-x revolving head type RD

**Type**

Clamping of 4 tool holders is possible. Manual pivoting, graduation catching every 9° = 40 positions.

**Scope of supply:**

Clamping wrench, pipe-head wrench, socket wrench.



21870 101-104

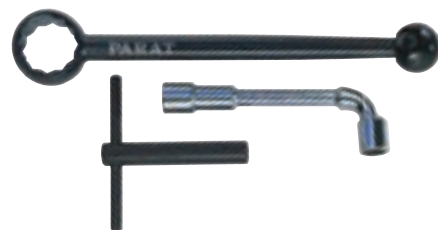

21870 201-204

Parat 4-fach turret head with internal cooling

Type RD/IK

**Type**

Clamping of 4 tool holders is possible. Manual pivoting, graduation catching every 9° = 40 positions.

**Scope of supply:**

clamping wrench pipe-head wrench, socket wrench, clamping screw with internal bore, cooling hose, connector, angle section, screw plug.

Clamping Technology

Technical specifications for determining size					
Size		1	2	3	4
Drive power for lathe, max.	KW	3.7	7.4	14.7	22
Rotary chisel cross-section max.	A	20	25	40	50
Height of cutting edge	B	30	40	60	80
Tool carriage width, min.	C	90 - 100	110 - 150	150 - 180	200 - 250
Turret head (square-section base unit)	D	84	106	134	154
Indexing disc with guard ring Ø	E	80	102	133	150
Turning circle with replaceable holder Ø	G	180	240	300	350
Clamping screw in support	J	M 14 x 2	M 16 x 2	M 20 x 2.5	M 24 x 3
	K	21	25	30	35
Weight approx. (without replaceable holder)	kg	3.5	6.5	15	22

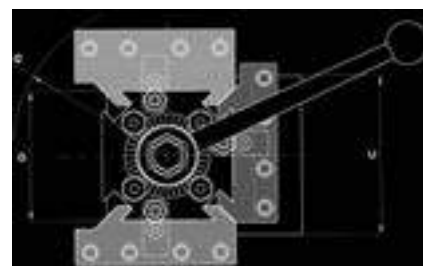
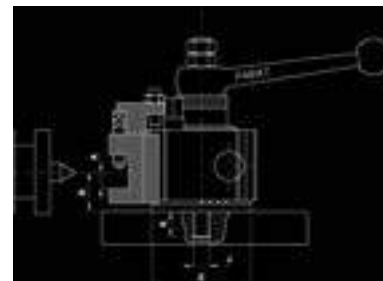

Size	Type RD		Type RD/IK		
	21870	...	21870	...	
1			101		201
2			102		202
3			103		203
4			104		204



**Use**  
Accessories for cat.-no. 21870.

**21871**  
**Quick-change toolholder type WD**  
**Use**  
For internal and external machining.

**21872**  
**Quick-change toolholder type WDL**  
**Use**  
For internal machining.

**21873**  
**Quick-change toolholder type WDR**  
**Use**  
For external machining.

**21874**  
**Quick-change toolholder type WDPL**  
**Use**  
For boring bars.

**21875**  
**Quick-change toolholder type WB**  
**Use**  
For mounting clamping sleeves  
(see cat.-no. 21877 - 21878).

**21876**  
**Quick-change toolholder type WBW (unfinished)**  
**Use**  
With soft, untreated clamping area for special tools.

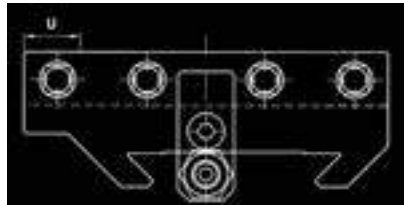
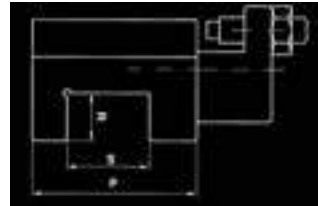
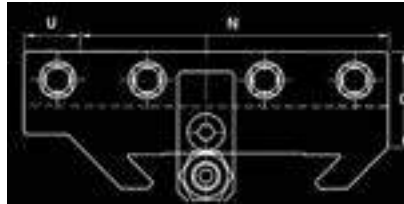

21871



21872



21873



21874



21875



21876

Type	Size	N	O	P	R	S	U	kg
WD	1/12	84	24	47	14	22	-	0.7
WDL/WDR	1/12	100	24	47	14	22	16	0.8
WD	1/20	84	33	52	20	22	-	0.8
WDL/WDR	1/20	100	33	52	20	22	16	0.9
WDPL	1/12	100	28	47	16	22	16	0.9
WB/WBW	1/30	84	39	47	30	-	-	0.8
WD	2/25	110	36	66	19	33	-	1.9
WDL/WDR	2/25	130	36	66	19	33	20	2.1
WDPL	2/25	130	50	62	31	33	20	2.3
WB/WBW	2/40	110	51	63	40	-	-	1.8
WD	3/32	140	44	76	25	33	-	3.0
WDL/WDR	3/32	165	44	76	25	33	25	3.4
WDPL	3/32	165	53	66	31	33	25	3.6
WD	3/40	140	44	76	25	43	-	3.1
WDL/WDR	3/40	165	44	76	25	43	25	3.4
WB/WBW	3/40	140	53	66	40	-	-	2.7
WB/WBW	3/50	140	63	76	50	-	-	3.5
WD	4/40	160	53	96	30	44	-	5.0
WDL/WDR	4/40	190	53	96	30	44	30	5.8
WDPL	4/40	190	63	96	40	52	30	6.5
WD	4/50	160	63	96	40	54	-	5.5
WDL/WDR	4/50	190	63	96	40	54	30	6.0
WB/WBW	4/60	160	77	96	60	-	-	6.0

Size	for turret head/size	Type WD		Type WDL		Typ WDR		Typ WDPL	
		21871	...	21872	...	21873	...	21874	...
1/12	type RD/1 and type UD/1		101		101		101		101
1/20	type RD/1 and type UD/1		102		102		102		102
2/25	type RD/2 and type UD/2		103		103		103		102
3/32	type RD/3 and type UD/3		104		104		104		103
3/40	type RD/3 and type UD/3		105		105		105		103
4/40	type RD/4 and type UD/4		106		106		106		105
4/50	type RD/4 and type UD/4		107		107		107		

Size	for turret head/size	Type WB		Typ WBW	
		21875	...	21876	...
1/30	type RD/1 and type UD/1		101		101
2/40	type RD/2 and type UD/2		102		102
3/40	type RD/3 and type UD/3		103		103
3/50	type RD/3 and type UD/3		104		104
4/60	type RD/4 and type UD/4		105		105

Clamping Technology

21877 - 21878 Clamping sleeves



21877

Type

Clamping sleeves for quick-change holder, type WB (see Cat. No. 21875).

Use

For mounting tools with MT shank.

21878

Type

Clamping sleeves, slotted for quick-change holders, type WB (see Cat. No. 21875).

Use

For clamping tools with straight shank.

for quick-change toolholder	MK	21877	...
Type WB 1/30	1		101
Type WB 1/30	2		102
Type WB 2+3/40	3		103
Type WB 2+3/40	4		104

for quick-change toolholder	MK	21877	...
Type WB 3/50	3		105
Type WB 3/50	4		106
Type WB 4/60	4		107
Type WB 4/60	5		108

Quick-change toolholder	inner Ø mm	21878	...
Type WB 1/30	8		101
Type WB 1/30	10		102
Type WB 1/30	12		103
Type WB 1/30	15		104
Type WB 1/30	16		105
Type WB 1/30	20		106
Type WB 1/30	25		107
Type WB 2+3/40	10		109
Type WB 2+3/40	12		110
Type WB 2+3/40	15		111
Type WB 2+3/40	16		112
Type WB 2+3/40	20		113
Type WB 2+3/40	25		114
Type WB 2+3/40	32		115
Type WB 3/50	20		117
Type WB 3/50	25		118
Type WB 3/50	32		119
Type WB 3/50	40		120
Type WB 4/60	25		123
Type WB 4/60	32		124
Type WB 4/60	40		125

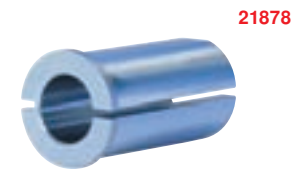
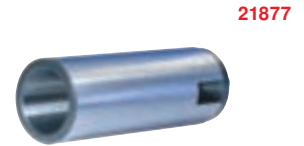

22950 - 22955 Taper Bore Cleaners

Type

- Made of impact-resistant plastic with felt lining inserted in slots and therefore protected against torsional stress
- Optimum oil and grease resistance
- High tolerance integrity

Use

For quick and thorough cleaning of tool adapters.

22950

For morse taper shank.

22951

For ST.

22955

For HSK tool mountings.



for taper MT	22950	...
1		301
2		302
3		303
4		304
5		305

for taper ST	22951	...
30		201
40		202
50		203

for taper HSK	22955	...
32		101
40		102
50		103
63		104
80		105
100		106



Steel holder head and change holder profile ground. Height adjustment of the steel through knurled screw on the steel holder without sheet metal underlay. Repeatability 0.01 mm. Easy release and arrest of the respective tool holder through eccentric clamping lever. 40 possible angles settings of the tools. Easy operation - short set-up times!

**Installation on the lathe:**

The steel holder head with ground gearing is fastened with the support screw. To do this, the centring disc must unscrewed to the dimension (tight fit not required) of the support screw. We recommend that you align the steel holder head with tensioned boring bar and turn-out bar at a right angle to the face plate. The steel holder head is secured in the support via 2 locating pins. The mark is then set to 0 and the nuts of the support screw are tightened appropriately.

**Pay attention to the following when selecting the size:**

1. Drive power of the lathe.
2. Required minimum dimension x.
3. The length of the change holder l should equal the width z of the upper support, if possible.
4. The steel height to be used h. Together with the steel height y and the remaining intermediate space underneath, it results in the required dimension x (see table).

**Example for selection of the size:**

Drive power of the machine	kW	6
Turning diameter of the machine	mm	500
Carriage width	z	mm 145
Steel height	h	mm 30
Cutting edge height	x	mm 45

**The following is required:**

Steel holder head	size B	(cat.-no. 21880 104)
Change holder	type B D 32 x 140	(cat.-no. 21882 211)
Change holder	type B H 30 x 130	(cat.-no. 21884 204)
Change holder	type B J 40 x 120	(cat.-no. 21886 205)
Change holder	type B A-A2a	(cat.-no. 21896 203)

**Required minimum dimension x for steel height h:**

The bore in the centring disc must be enlarged to the dimensions of the clamping screw.

Size	Aa		A		E		B		C			D 1		
Steel height	x													
h mm	D 12	D 16	D 20	D 20	D 25	D 25	D 32	D 32	D 40	D 45	D 40	D 50	D 63	
6	12													
8	14	18												
10	16	20	20	20	22									
12	18	22	22	22	24	24	25							
16		26	26	26	28	28	29	31	32,5	32,5				
20					30	32	33	35	36,5	36,5				
25					37	37	38	40	41,5	41,5	45			
32							45	47	48,5	48,5	52	52	52	
40									56,5	56,5	60	60	60	
45										61,5		65	65	
50												70	70	
63													83	

**Technical data:**

cat.-no.	21880...	101	102	103	104	105	106						
Size	Aa	A		E		B		C			D 1		
Change holder size	D 12	D 16	D 20	D 20	D 25	D 25	D 32	D 32	D 40	D 45	D 40	D 50	D 63
Drive power of the machine approx. kW	1,2	2,2		5,0		6,6		13,2				22,0	
Turning diameter of the machine mm	120-220	150-300		200-400		300-500		400-700				600-1000	
Carriage width max. z mm	80	100		120		150		180				200	
Cutting edge height min. x mm	h + y	h + y		h + y		h + y		h + y				h + y	
Cutting edge height max. mm	x + hv	x + hv		x + hv		x + hv		x + hv				x + hv	
Height adjustability hv mm	8	11		17	15	20	11	40	35	30	35	30	20
Steel support y mm	6,2	9,1	10,1	10,5	12	12	13,5	17	18	18		20,5	
Support width for work steel d mm	10	14	16	16	20	20		21	30,5	30,5	30	34	40
Height of the work steel max. h mm	12	16	20	20	25	25	32	32	40	45	40	50	63
Total width max. v mm	70	100		125		150		192	202	202	230	234	242
Total height s mm	32	54		68		75		105				122	
Projection max. u mm	30	48		60		71		92	102	102	112	117	124
Bore normal t mm	12	20		20		32		40				40	
Bore max. t mm	12	32		42		51		74				82	
Depth of the bore max e mm	-	35		35		45		75				75	
Weight without change holder kg	0,34	1,2		3,5		4,5		10,7				18,0	

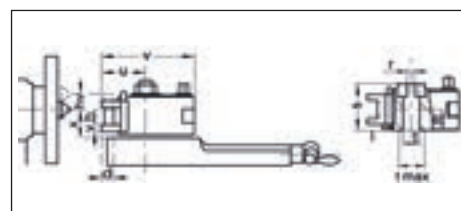
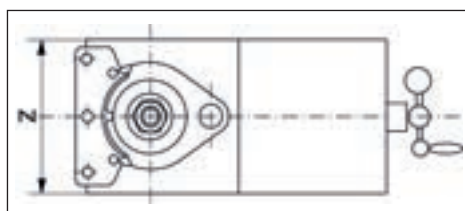

Clamping Technology

21880

Toolheads



Use  
For mounting toolholders.

Note:  
Technical data, see Info quick-change-steel holder on previous page.  
Spare parts see cat.-no. 21898.

21880



Size	21880	...
Aa		101
A		102
E		103
B		104
C		105
D 1		106

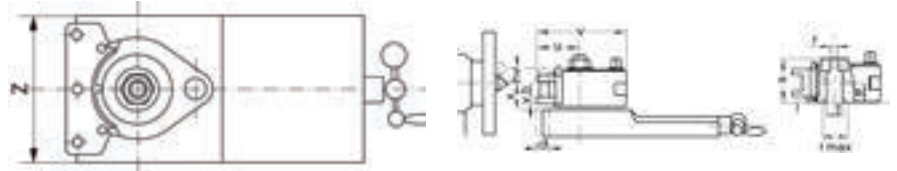

21882

Toolholders D



Use  
For mounting tool bits with square shank.

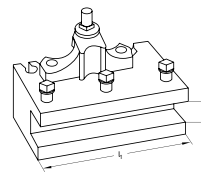

21882



Type	for size	a mm	l <sub>1</sub> mm	21882	...
Aa D 12 x 50	Aa	12	50		201
A D 20 x 75	A	20	75		204
A D 20 x 90	A	20	90		205
E D 20 x 100	E	20	100		206
E D 25 x 100	E	25	100		207
B D 25 x 120	B	25	120		208
B D 25 x 140	B	25	140		209
B D 32 x 120	B	32	120		210
B D 32 x 140	B	32	140		211

Type	for size	a mm	l <sub>1</sub> mm	21882	...
C D 32 x 150	C	32	150		212
C D 32 x 170	C	32	170		213
C D 40 x 150	C	40	150		214
C D 40 x 170	C	40	170		215
C D 45 x 170	C	45	170		216
D 1 D 40 x 180	D 1	40	180		217
D 1 D 50 x 180	D 1	50	180		218
D 1 D 63 x 180	D 1	63	180		219

21884

Toolholders H



Use  
For mounting tool bits with round shank.

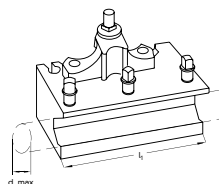

21884



Type	for size	d max mm	l <sub>1</sub> mm	21884	...
Aa H 12 x 50	Aa	12	50		201
A H 20 x 85	A	20	85		202
E H 30 x 100	E	30	100		203
B H 30 x 130	B	32	130		204

Type	for size	d max mm	l <sub>1</sub> mm	21884	...
C H 40 x 160	C	40	160		205
C H 50 x 160	C	50	160		206
D 1 H 63 x 180	D 1	63	180		207

21886

Toolholders J



Use  
For mounting boring bars und round tool bits.

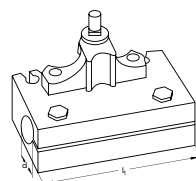

21886



Type	for size	Borehole d mm	l <sub>1</sub> mm	21886	...
Aa J 15 x 50	Aa	15	50		201
A J 30 x 80	A	30	80		202
E J 30 x 100	E	30	100		203
E J 40 x 100	E	40	100		204

Type	for size	Borehole d mm	l <sub>1</sub> mm	21886	...
B J 40 x 120	B	40	120		205
C J 40 x 160	C	40	160		206
C J 50 x 160	C	50	160		207
D 1 J 63 x 180	D 1	63	180		208

21888

## Sleeves L

**ATORN®**

## Type

With internal taper.

## Use

For boring bar toolholders cat.-no. 21886.

21888

Type	for size	d mm	Taper MT	21888	...
L 30 x 2	A/E	30	2		201
L 40 x 3	E/B/C	40	3		202
L 40 x 4	B/C	40	4		203
L 50 x 3	C	50	3		204
L 50 x 4	C	50	4		205
L 63 x 5	D 1	63	5		206

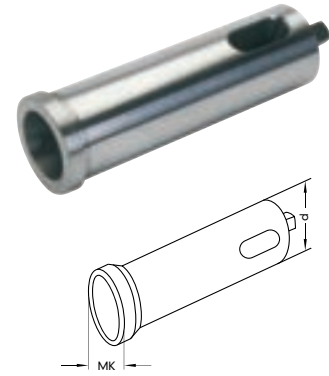

21894

## Prism Inserts P

**ATORN®**

## Use

For tool holder cat.-no. 21884.

21894

Type	for size	d max. mm	l <sub>1</sub> mm	21894	...
A P 14 x 85	A	14	85		101
E P 14 x 100	E	14	100		102
B P 20 x 130	B	20	130		103
C P 25 x 160	C	25	160		104
C P 32 x 160	C	32	160		105
D 1 P 40 x 180	D 1	40	180		106

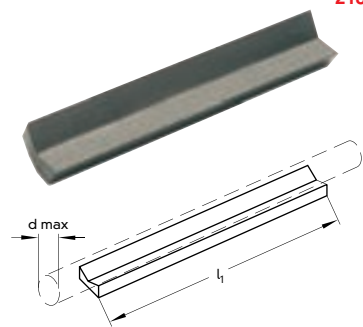

21896

## Cutting-Off Toolholders A

**ATORN®**

## Use

For mounting KOMET cutting-off tool bits.

21896

Type	for size	KOMET size	Cross-section mm	21896	...
AA-AO	A	A0	10 x 2.7		201
EA-AO	E	A0	10 x 2.7		202
BA-A2a	B	A2a	16 x 4/3		203
CA-A3a	C	A3a	18.5 x 5/4		204



21898

## Spare Parts for Toolholders

**ATORN®**

## Use

For cat.-no. 21880 - 21886 and 21896.

21898

Description	for tool holder type	21898	...
Clamping lever 8 mm	Aa		201
Clamping lever 12 mm	A		202
Clamping lever 17 mm	E/B/C		203
Clamping lever 22 mm	D 1		204
Square head screw	Aa		210
Square head screw	A/E		211
Square head screw	B		212
Square head screw	C/D 1		213
Height adjustment screw with nut	Aa		301
Height adjustment screw with nut	A		302
Height adjustment screw with nut	E		306
Height adjustment screw with nut	B		303
Height adjustment screw with nut	C		304
Height adjustment screw with nut	D 1		305

